

1-4 East Road



Site Lighting Report

18_D064 1-4 East Road

April 2019

ethos
ENGINEERING

1-4 East Road Site Lighting Report

18_D064 1-4 East Road

CURRENT ISSUE			
Issue No:	P3	Issue Date:	19/04/2018
Sign Off	Originator:	Checker:	Reason For Issue:
Print Name:	Raul Turcu	Peter Farrell	Issue for Planning

PREVIOUS ISSUES (Type Names)				
Issue No:	Date:	Originator:	Checker:	Reason For Issue:
P2	14/12/2018	Raul Turcu	Peter Farrell	Issue for Planning
P1	30/11/2018	Raul Turcu	Peter Farrell	Draft Issue for Planning
P0	26/11/2018	Raul Turcu	Peter Farrell	Draft Issue for Planning

Table of Contents

1.0	Executive Summary	1
2.0	Design Criteria	2
3.0	Proposed Site Lighting Installation.....	3
4.0	Simulation Results	5
5.0	External Site Light Overspill	6
	APPENDIX 1: External Luminaire Schedule	9
	APPENDIX 2: Site Lighting Drawing (A1)	14

1.0 Executive Summary

The application consist of the demolition of all existing structures on site and the construction of a mixed use development with a gross floor area of c. 52,769 sq.m (excluding below podium parking areas) set out in 9 no. blocks, over two separate podium, ranging in height from 3 to 15 storeys to accommodate 554 no. apartments commercial/enterprise space, 3 no. retail units, foodhub/café/exhibition space, residential tenant amenity, crèche and men's shed. The site will accommodate 241 no. car parking spaces, 810 no. bicycle parking spaces, storage, services and plant areas. Landscaping will include a new central public plaza and residential podium courtyards.

This external lighting report is based upon the following requirements;

- Provide adequate illumination to contribute towards the safe use of the site by both vehicles and pedestrians.
- Enhance site security.
- Provide a visually interesting environment.
- Contain the lighting within the site to lighting levels which will not impact on the neighbouring surroundings.
- Safe access to fire assembly points.
- Minimise light pollution, sky glow and visual glare for pedestrians and surrounding areas.

The external lighting is designed using the lighting simulation software DIALux and is in accordance with the following:

- CIBSE Lighting Guide LG – 6
- IS EN 12464-2
- CIE Guide regarding Illumination levels and "Obtrusive Light" to neighbouring properties
- HSA Regulations for Electricity
- ETCI National Rules for Electrical Installations ET 101 2008

2.0 Design Criteria

The design criteria is based upon the following:

Area	Lighting Levels (Lux)
Car Park	20
Public Walkways	10
Public Roadways	20
Stairs	100
Courtyard	20
Overspill Areas	5

3.0 Proposed Site Lighting Installation

The proposed site lighting installation comprises of 6 metre high post top column lighting to car park roads/ parking spaces and 1000mm bollard lighting to pedestrian walkways.

The proposed 6m column with post top luminaires will illuminate the car park areas to achieve an average illumination level of 20 lux. The photometric curve enclosed within Appendix 1 figure 5 for the proposed LED luminaire to the car park area, indicates how the light output is directed downwards with no risk of "sky glow".

It is proposed to provide 1000mm bollard type light fittings to pedestrian walkways to achieve an average illumination level of 20 lux at ground level.

It is proposed to provide 4 meter high column LED luminaires for the courtyard to achieve the 20 lux requirement at ground level.

It is proposed to provide recessed mounted floorwash LED luminaires to the bench areas to achieve the required 20 lux at ground level.

It is proposed to provide wall mounted luminaires for the stairs to achieve the 100 lux requirement to comply with Part M requirements.



Fig 1 - 3D - Typical Location of Bollard

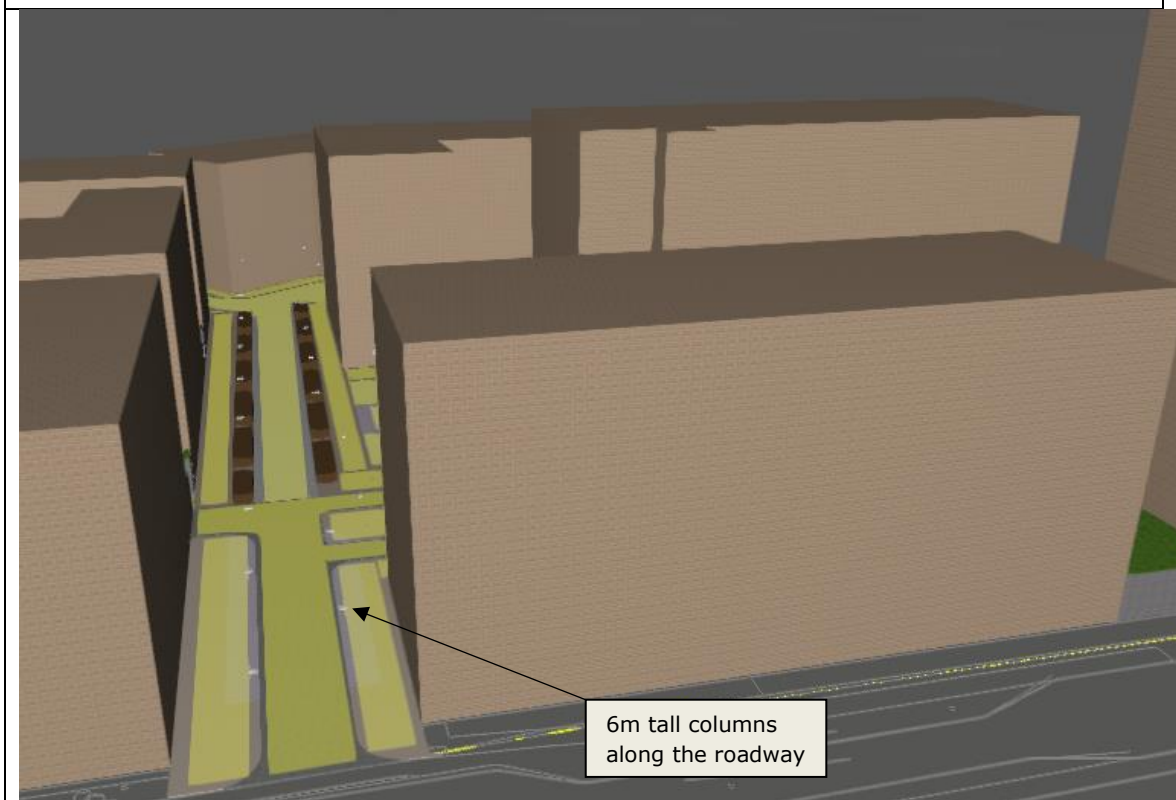

Fig 2 - 3D - Typical Location of 6m Columns

Refer to Appendix 2 for location of all luminaires.

4.0 Simulation Results

Figure 3 below indicates the illumination lighting levels at car park and road area. Illumination is indicated using a colour scale.

The roadway illumination achieves over 20 Lux average. In accordance with CIBSE requirements.

There is light overspill to the neighbouring properties of below 5 lux, which in our opinion is satisfactory. The light spill is caused by the requirements of lighting along the pathways.

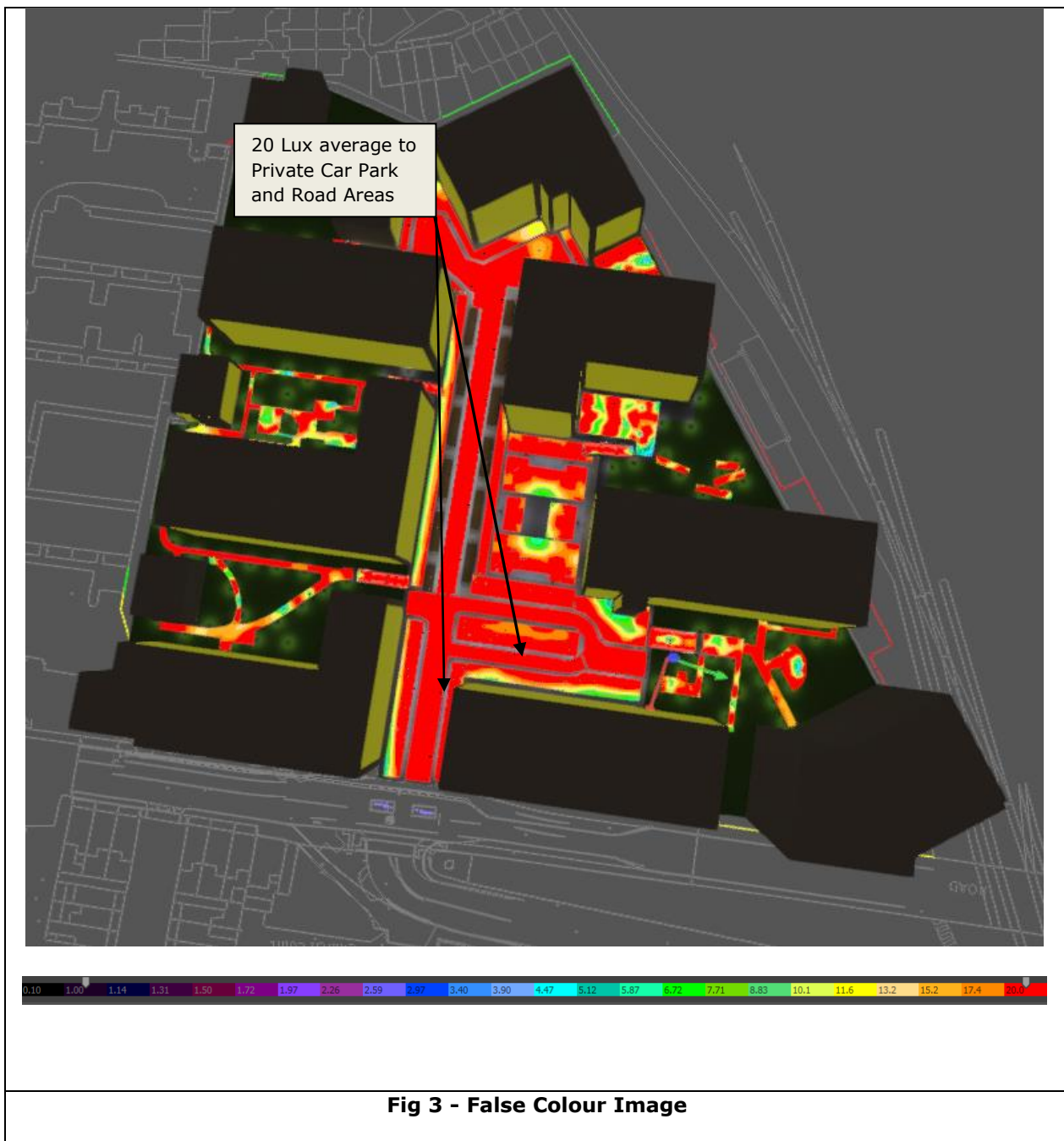

5.0 External Site Light Overspill

Figure 4 indicates the illumination levels on the neighbouring properties from the proposed luminaires. From the analysis the maximum illumination achieved is 5 lux which is within the design guidelines, CIE Guide regarding Illumination levels and "Obtrusive Light" to neighbouring properties.

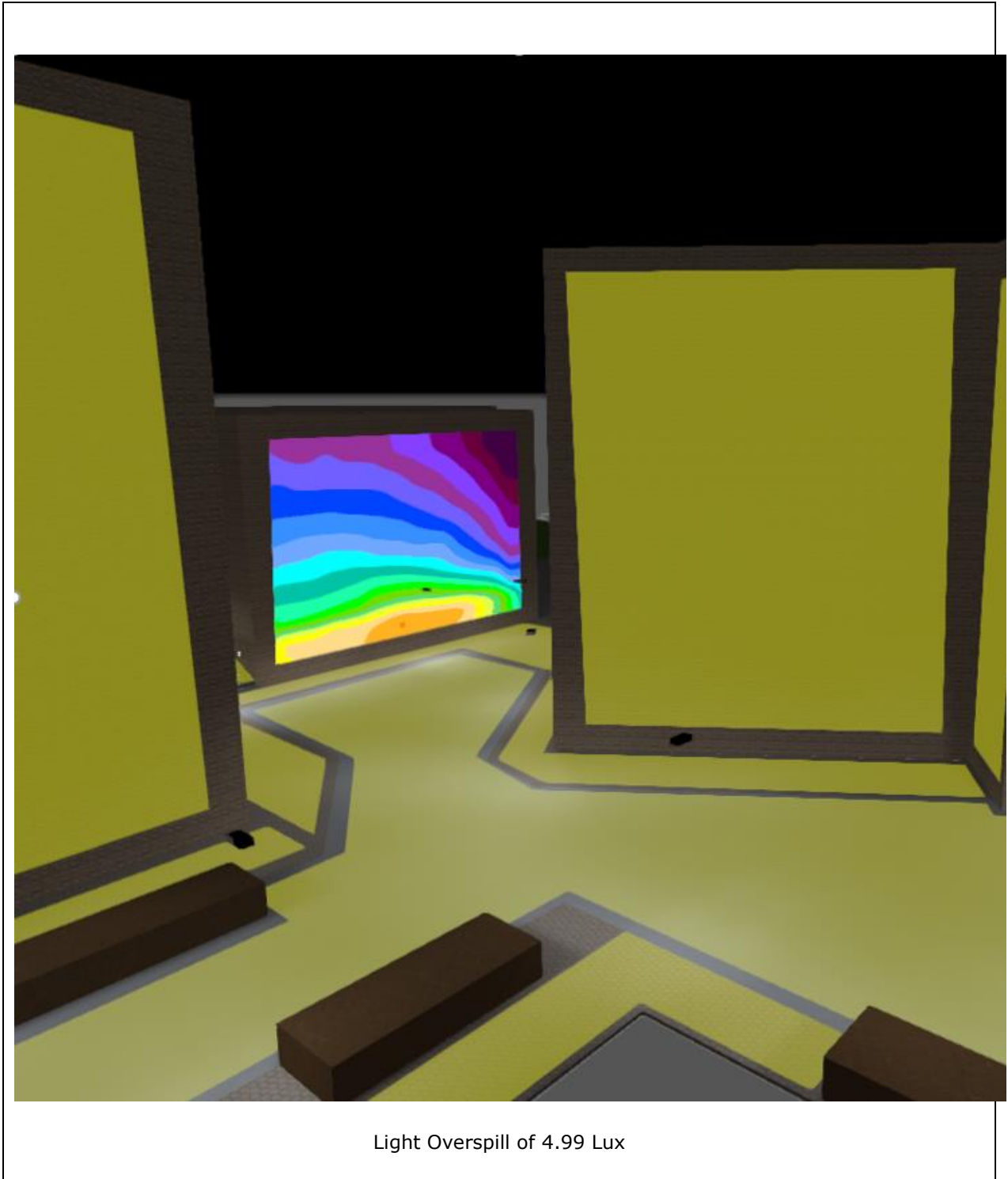

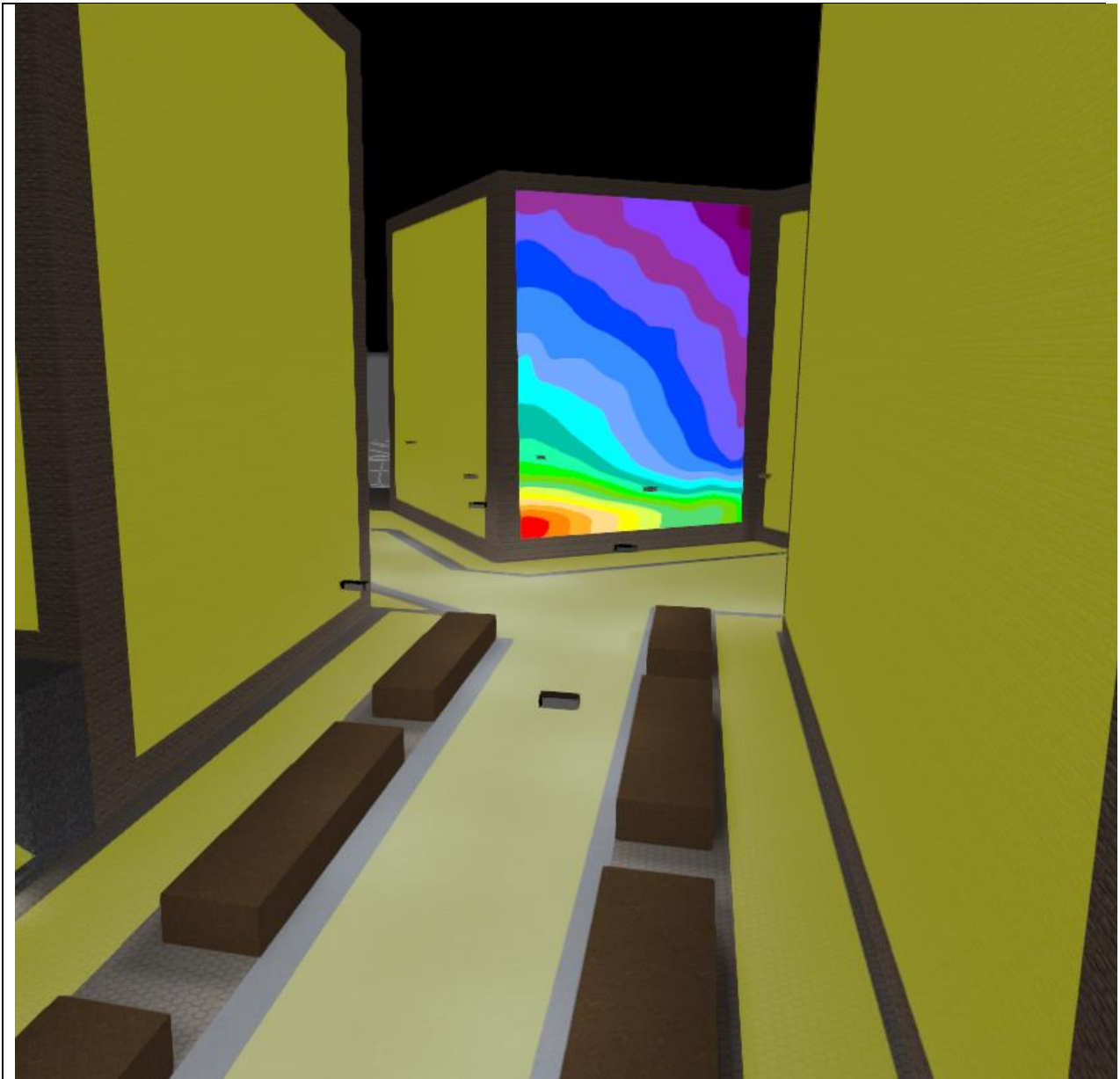

Light Overspill of 4.54 Lux

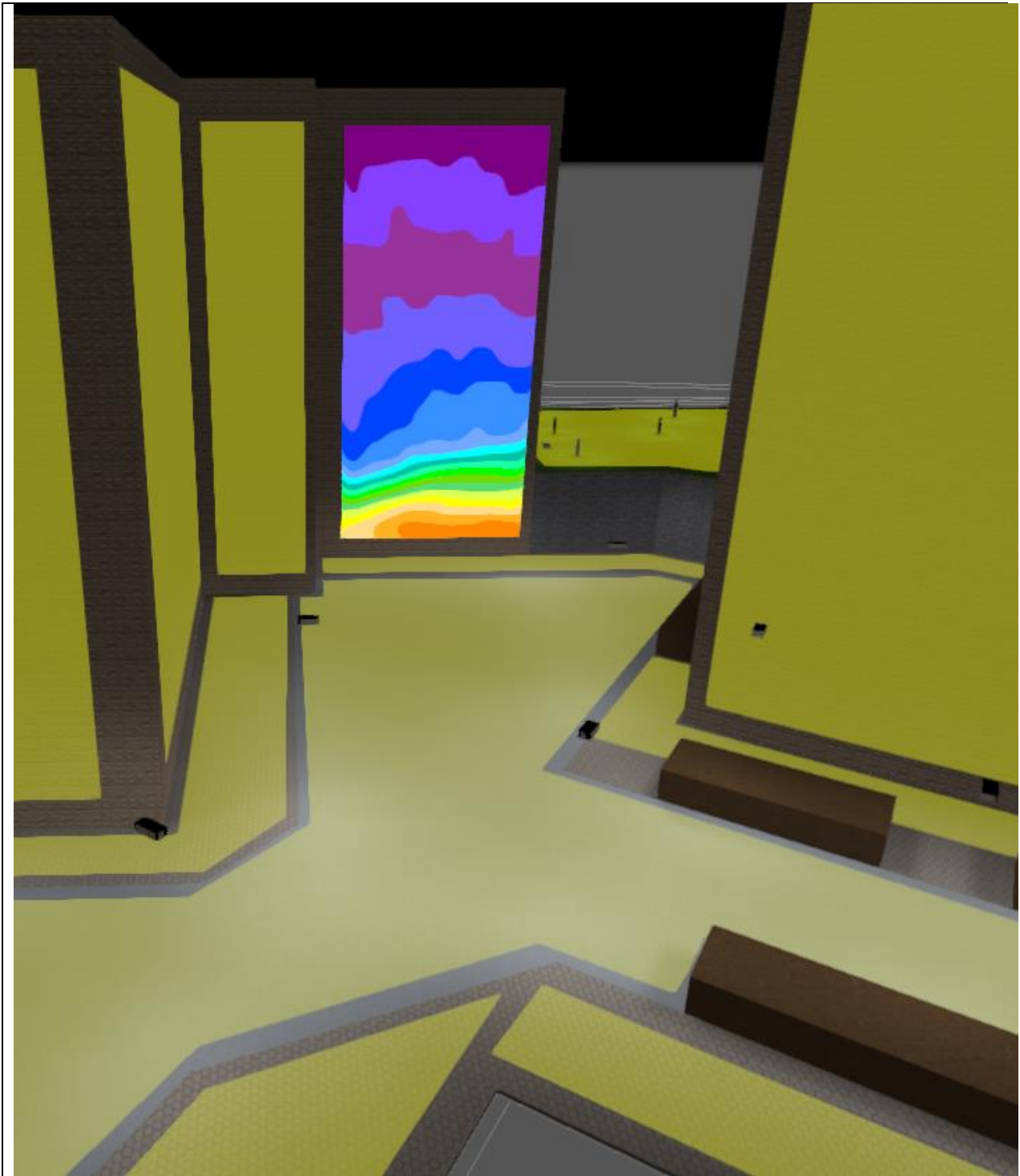

Light Overspill of 4.51 Lux

Fig 4 - Areas with the highest light overspill

APPENDIX 1: External Luminaire Schedule

	Image	Photometric Curve	Description
Type A			<p>6 Meter column light fittings to be used along the roadway.</p> <p>The indicative luminaire selected would be provided with 51 Watt LED lamp module, with a lamp output of 5,500 lumens.</p> <p>The photometric curve displayed indicates how all light output is directed downwards; i.e. no risk of sky glow</p>
	<p>Dimensions of Luminaire</p>		
			
<p>Fig 5 – Proposed 6 Meters Columns for Roadways</p>			

	Image	Photometric Curve	Description
<p>Type A1</p>			<p>4 Meter column light fittings to be used in the courtyard.</p> <p>The indicative luminaire selected would be provided with 40 Watt LED lamp module, with a lamp output of 4,200 lumens.</p> <p>The photometric curve displayed indicates how all light output is directed downwards; i.e. no risk of sky glow</p>
	<p>Dimensions of Luminaire</p> 		

Fig 6 – Proposed Courtyard Luminaire

	Image	Photometric Curve	Description
Type B			<p>900mm high bollard light fittings installed in the amenity areas of the site to light up the walkways.</p> <p>The indicative luminaire selected would be provided with 29 Watt LED lamp module, with a lamp output of 701 lumens.</p>
	<p>Dimensions of Luminaire</p> 		

Fig 6 – Proposed Walkways Luminaire

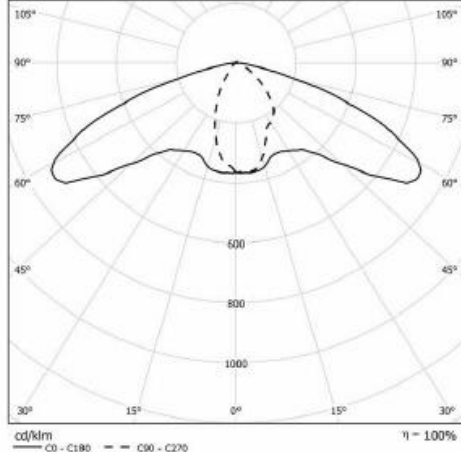
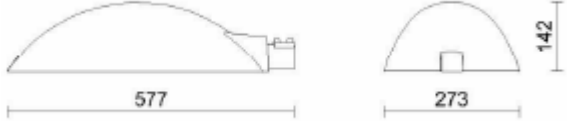
	Image	Photometric Curve	Description
Type C			<p>Wall recessed floorwash fittings installed in the side walls of the stairs.</p> <p>The indicative luminaire selected would be provided with 8 Watt LED lamp module, with a lamp output of 435 lumens.</p>
	<p>Dimensions of Luminaire</p>		
			
<p>Fig 8 – Proposed Stairs Luminaire</p>			

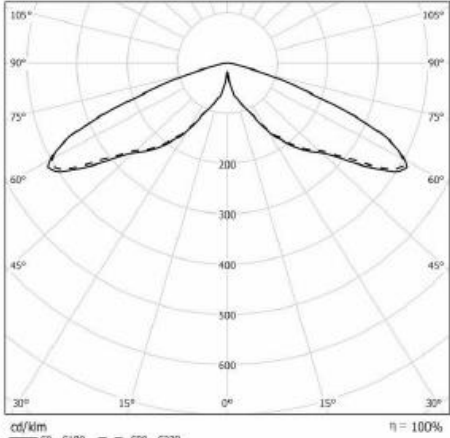
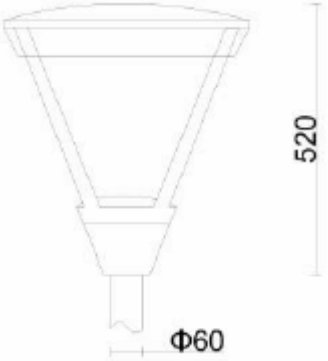
	Image		Description
<p>Type F</p>		 <p>h=0.10m MF=1.00</p> <p>0.5 2 10</p> <p>m 1.6 1.2 0.8 0.4</p> <p>m 0.8 0.4 0.0 0.4</p>	<p>Recessed floorwash fittings installed in the benches side walls</p> <p>The indicative luminaire selected would be provided with 2 Watt LED lamp module, with a lamp output of 35 lumens.</p>
	<p>Dimensions of Luminaire</p>		
			

Fig 10 – Proposed Recessed Luminaire

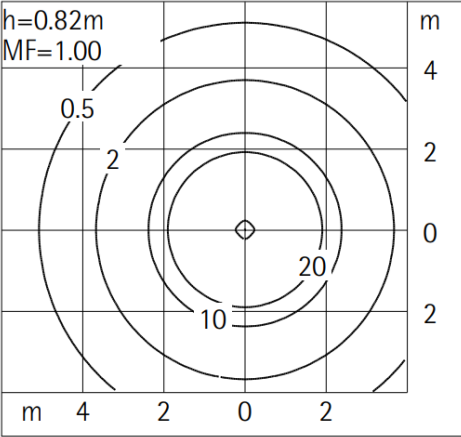
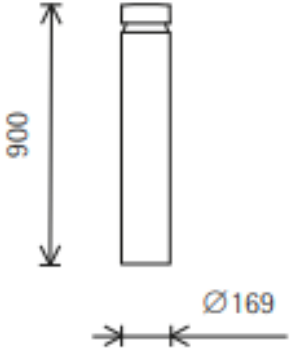
APPENDIX 2: Site Lighting Drawing (A1)

ethos

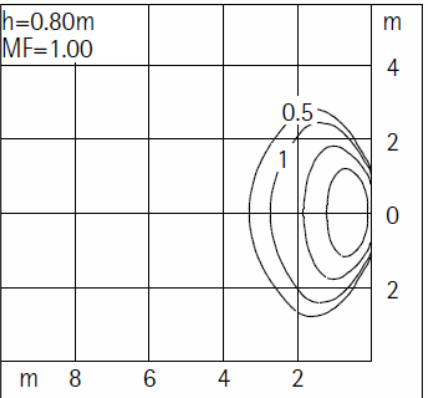
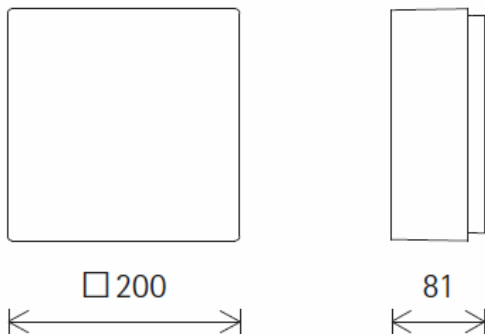
ENGINEERING

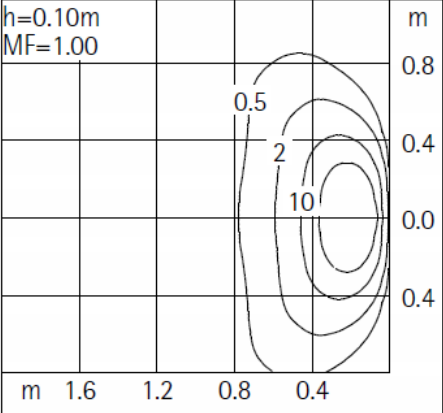
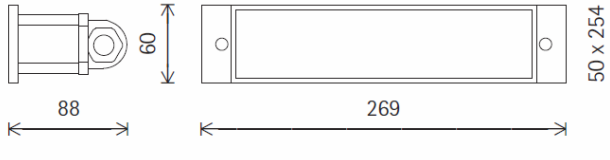
Penthouse Suite, Apex Business Centre,
Blackthorn Road, Sandyford,
Dublin 18, Ireland

Phone +353 (0) 1 293 2220
Web www.ethoseng.ie

